

IMPREZA



SUBARU

Confidence in Motion





MORE CAPABLE. MORE RESILIENT. MORE REWARDING.

Introducing the new SUBARU Impreza. The fresh, dynamic exterior styling, premium interior finishes and cutting-edge safety technologies are just the start. Built using the innovative SUBARU Global Platform, both the body and chassis have been entirely re-engineered - increasing strength and improving safety and handling. And now Impreza's proven combination of SUBARU Boxer Engine, Symmetrical All-Wheel Drive and Lineartronic Continuously Variable Transmission (CVT) is available in 1.6i or 2.0i configurations.



PASSIONATELY ENGINEERED.
PRECISION-BUILT.



SUBARU Impreza fuses bold design with driving capability, safety and control. Engineering and craftsmanship go hand-in-hand. An aerodynamic roofline allows for a spacious interior. The distinctive hexagonal grille flows through to the steering-responsive LED headlights. Entry is keyless - a touch sensor on the driver's door handle opens and locks the car. Once the brake pedal is depressed, an interior button starts the engine.

TRUST IN SUBARU.

Wherever you go, whatever you do, Impreza has you and your passengers covered. The cutting-edge SUBARU Global Platform delivers a body that is 40% stronger, allowing the frame to absorb and safely dissipate more energy in the event of a collision. By increasing rigidity of the body, front suspension and rear subframe, the SUBARU Impreza has enhanced straight-line stability and minimal body roll.





**DRIVE. DISCOVER.
EXPLORE.**



VERSATILE DESIGN FOR THE THINGS YOU ENJOY.

For work or play, Impreza offers ample space to take everything you'll need for the things you love to do. Whether it's a sporting fixture or a family trip, Impreza has the capacity to transport passengers in comfort and equipment or luggage with ease.



Rear boot space

The luggage space of Impreza is now 5 litres larger. With a bigger opening, wider compartment and 60/40 split folding rear seats, it's easily accessible - perfect for busy on-the-go lifestyles.



STYLE, COMFORT, AND ENJOYMENT FOR ALL.

Introducing a new level of refinement, Impreza reveals a quiet, roomy cabin rich in sculpted surfaces and careful attention to detail. Stitching and metallic inlays trace dynamic lines, complemented by metallic casings on the instrument panel, steering wheel and gearshift. Passengers enjoy generous, supportive front and rear seating – ideal for long journeys.

01. Rear Armrest with Cup Holders

The interior of Impreza offers comfort for all passengers, with cup holders in the rear seat centre armrest.

02. Front Seats

Impreza features redesigned, stylish front seats that offer more support and comfort for a relaxing journey.



STAY IN TOUCH. FEEL CONNECTED.

It's a fast-paced world we live in. That's why Impreza is equipped with a completely redesigned next-generation infotainment system that keeps you connected wherever you go. The 8" multi-function colour touchscreen head unit display provides intuitive access to connected devices and audio sources, whilst a redesigned multi-information display informs drivers of key vehicle stats. These displays all improve convenience, safety, and enjoyment. In touch and in control - that's how you'll always feel inside Impreza.



01. Apple CarPlay™ and Android Auto™*1

Use today's most popular apps with Apple CarPlay™ and Android Auto™. Voice recognition*2 capabilities allow hands-free use, keeping everybody safe whilst reducing distractions when you're on the road.

02. Multi-information Display

The 4.3" LCD multi-information display at the top of the instrument panel provides you and your passengers with useful information in an easy-to-understand view. It offers a fuel economy screen; eco-evaluation screen; driving condition; and clock with outside temperature and maintenance information.

03. Meter Display

Now easier to see with its larger screen, the full-colour LCD meter display helps you understand useful driving information at a glance so you can keep your eyes on the road.

04. Reversing Camera

When you engage reverse gear, the reversing camera displays a live colour image along with guidelines to assist in parking manoeuvres.

*1 Driver is responsible for safe driving. Please refrain from operating the touchscreen while driving.

*2 Voice Recognition is compatible with select languages only.

SUBARU CORE TECHNOLOGY.

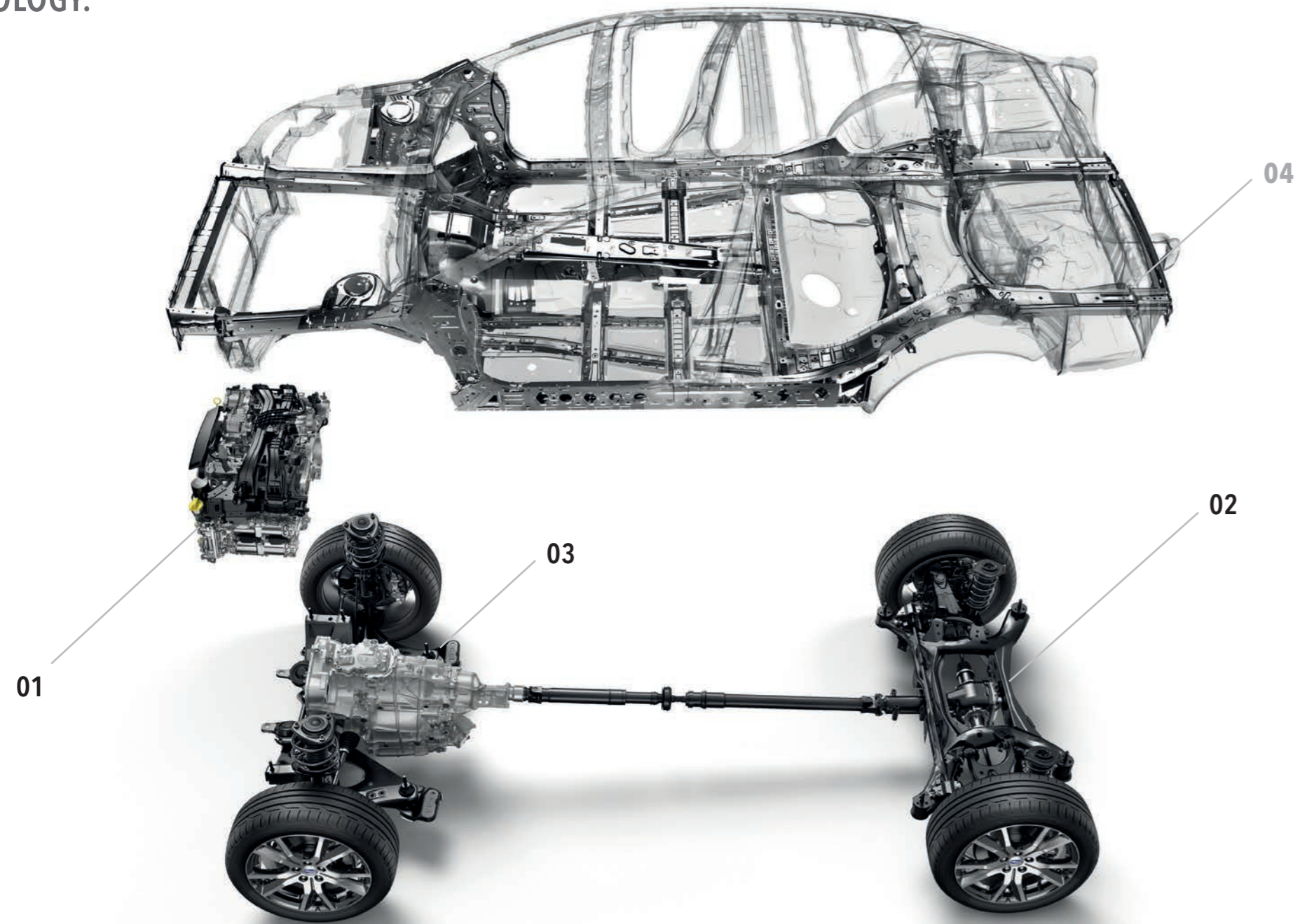

SUBARU's core technologies define what makes a SUBARU a SUBARU - and the unique driving experience that only our vehicles can provide. These core systems enable SUBARU vehicles to live up to the brand's exceptional standards of performance, comfort, safety, and reliability. They also underpin SUBARU's promise to deliver both driving enjoyment and peace of mind.

01 | SUBARU BOXER ENGINE

The horizontally-opposed configuration of the SUBARU Boxer engine places the pistons 180 degrees apart for a lower, flatter profile than other engine types. This gives the powerplant - and therefore the whole car - a lower centre of gravity. More balanced weight distribution promotes exceptional handling and poise. And, as the opposing 'Boxer' piston movements naturally counteract each other, they reduce engine vibration and noise too, delivering a smoother driving experience.

02 | SYMMETRICAL ALL-WHEEL DRIVE

SUBARU's Symmetrical AWD distributes power to all four wheels for better traction on wet and slippery roads. The entire drive system, from the Boxer engine and transmission to the rear differential, is mounted in a straight, symmetrical line allowing maximum power transfer to all four wheels at all times. This well-balanced low centre of gravity design delivers a more stable and safer ride.

03 | LINEARTRONIC + ACTIVE TORQUE SPLIT AWD

Lineartronic adjusts to any ratio in its range for smooth and stepless gear changes that keep the engine in its most efficient range for smooth acceleration, driving performance and better fuel efficiency. It comes paired with SUBARU's active torque split AWD system. Its default torque of 60% front and 40% rear is adjusted up to a 50/50 split in response to real-time traction conditions.

04 | SUBARU GLOBAL PLATFORM

The SUBARU Global Platform (SGP) is the underlying platform that will underpin the next generation of SUBARU vehicles. Enhancing all-around safety and performance, it offers a driving experience you can only find in a SUBARU. It's the future of SUBARU - and delivers even more enjoyment and peace of mind to all drivers and passengers.

1. Improved Safety Performance

Body strength is increased by 40%. In the event of a collision, the frame can absorb and safely dissipate more energy. The new frame design also improves energy dispersal, directing more energy safely beneath the seating compartment.

2. Better Stability and Handling

By increasing rigidity of the body, front suspension and rear subframe, Impreza has enhanced straight-line stability and minimal body roll. More responsive handling allows the driver to better steer the car as intended and improves hazard avoidance.

3. Enhanced Ride Quality

Vibrations and noise have been minimised to improve passenger comfort. Suspension improvements and a highly rigid chassis provide a quiet, comfortable journey for all.

A PERFECTLY-BALANCED CONFIGURATION

Conventional 4-cylinder engines use pistons that either move up and down vertically, or in a V-shape. This approach makes such engines tall. They sit upright, above the wheel-line compromising vehicle stability. Transverse engine designs are also heavier on one side. They may require balancer shafts - adding unnecessary weight and complexity. In contrast, because the Boxer engine block has a flatter profile and sits lower, centrally in the chassis, a SUBARU is more stably balanced. It's more resistant to side-to-side motion and roll when cornering, offering better handling and performance.

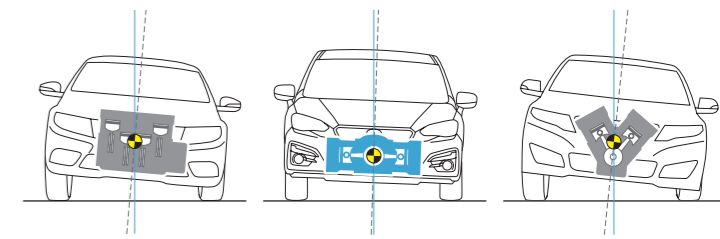
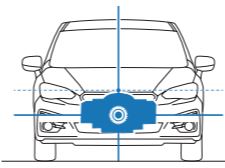



01 SUBARU REAR VEHICLE DETECTION*1
 SUBARU Rear Vehicle Detection (SRVD) includes Blind Spot Monitoring, Lane Change Assist & Rear Cross Traffic Alert. Sensors placed at the rear of the vehicle alert you of vehicles in your rear blind spots for safer lane changes and can also warn you of potential collision danger when reversing out of a parking space.

03 VISIBILITY
 Design improvements have been made with the viewing angle of the driver in mind to offer better front and rear visibility.

SUBARU GLOBAL PLATFORM (SGP)

The SGP's enhancements throughout the chassis - higher rigidity, increased strength, better rolling resistance and responsive steering - particularly benefit these safety systems.

02 HIGH BEAM ASSIST*1
 High Beam Assist (HBA) increases visibility and safety when driving at night by automatically toggling the high beams on and off when oncoming traffic is detected.

04 VEHICLE DYNAMICS CONTROL SYSTEM
 The Vehicle Dynamics Control System monitors and analyses if the vehicle is following the driver's intended course via an array of sensors. If a tyre slips or the vehicle begins to veer from its intended path, the All-Wheel Drive torque distribution, engine output, and brakes at each wheel are adjusted to assist in keeping the vehicle on course.

05 HAZARD AVOIDANCE
 The lower centre of gravity design, enhanced suspension system, and rigidity improvements provide a vehicle that responds immediately when evasive actions are taken, helping you to avoid hazards on the road.

06 CABIN-PROTECTING LAYOUT
 In the event of a collision, the low-mounted engine and gearbox are designed to both absorb the impact and drop safely below the passenger compartment, protecting occupants' legs. To allow for this movement, the cradle securing the engine is engineered to collapse, allowing the engine to slide downwards.

07 RING-SHAPED REINFORCEMENT FRAME
 The Ring-shaped Reinforcement Frame makes better use of high tensile steel panels and has been structurally redesigned for more efficient energy absorption from impacts in all directions.

09 WHIPLASH-REDUCING FRONT SEATS
 Designed to enhance comfort and help the driver feel more planted for greater control, these seats can also help reduce the possibility of whiplash resulting from certain types of collisions.

08 SRS AIRBAGS*2
 Front SRS*2 airbags, front side SRS*2 airbags, curtain SRS*2 airbags, and a knee SRS*2 airbag are standard on Impreza to give all passengers a higher level of protection in the event of a collision.

10 LOCKING-TONGUE SEATBELTS
 During an impact, the locking tongue limits movement in the seatbelt and reduces impact in the lower chest area to improve safety and reduce injury levels.

ACTIVE SAFETY

PASSIVE SAFETY

*1 The driver is always responsible for safe and attentive driving and observance of traffic regulations. Please do not depend solely on Subaru Rear Vehicle Detection or High Beam Assist for safe driving. There are limitations to the recognition features of these systems. See Owner's Manual for complete details on system operation and limitations.
 *2 SRS: Supplemental Restraint System. Must be used with seatbelts.

SUBARU'S WORLD-LEADING DRIVER ASSIST TECHNOLOGY.

At SUBARU, we believe in all-around safety. An important part of that is pre-collision safety: making every effort to ensure an accident never happens. That's why we created EyeSight*, SUBARU's cutting-edge driving support system. Like a second pair of eyes for the road ahead, EyeSight uses two stereo cameras capturing three-dimensional colour images with excellent image recognition, nearly as capable as the human eye. More accurate than traditional camera and sensor technologies, EyeSight uses images from both cameras to precisely determine shape, speed and distance, meaning it not only detects vehicles but also motorbikes, bicycles and pedestrians*. When a potential hazard is identified, it warns the driver and even applies the brakes if necessary, to help avoid an accident. With excellent safety performance, EyeSight gives the driver ultimate peace of mind.

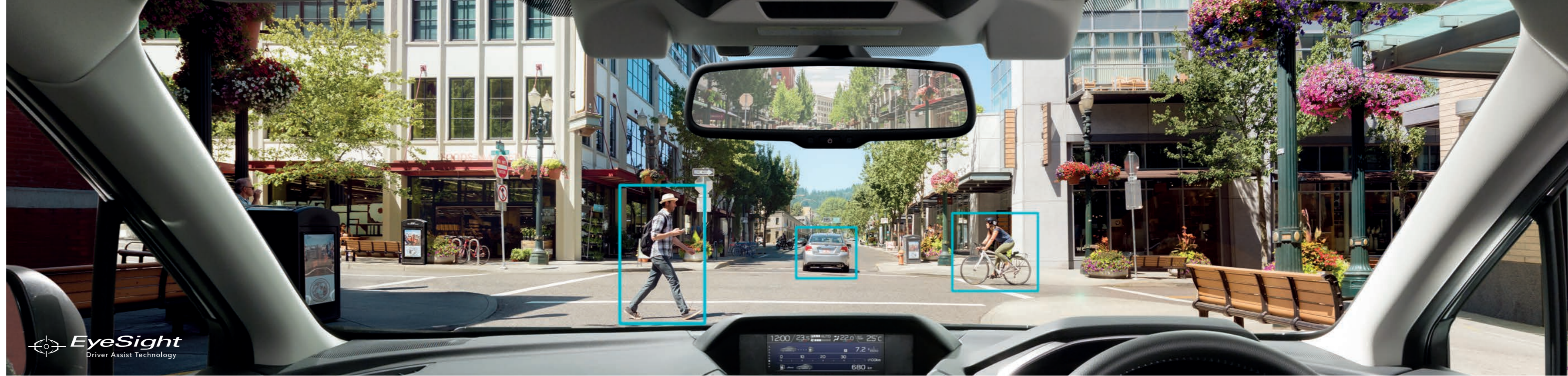

EyeSight
Driver Assist Technology

DRIVER ASSIST

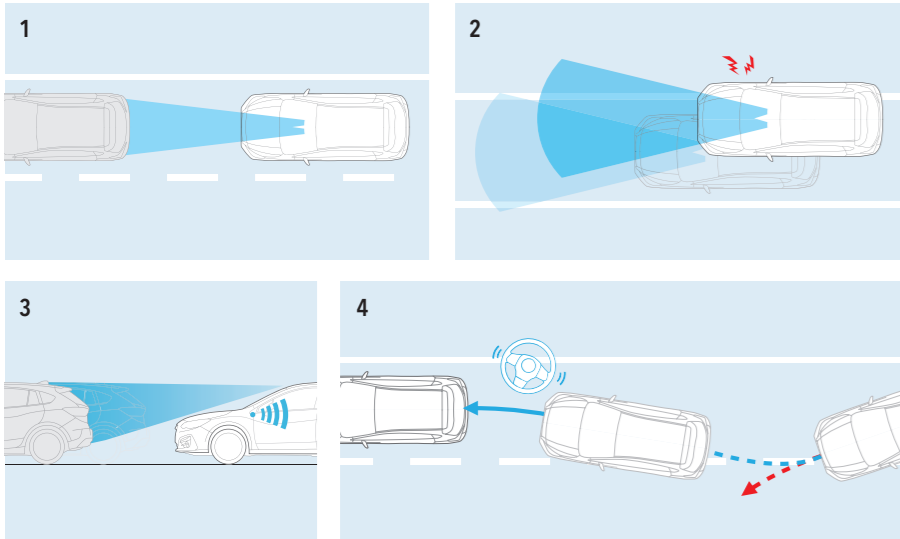

1. ADAPTIVE CRUISE CONTROL

Adaptive Cruise Control allows the driver to set vehicle speed and distance to the car in front. It constantly monitors distance and speed then adjusts the engine, transmission and brakes accordingly to maintain speed in line with the traffic flow. Designed for use on motorways and similar roads, Adaptive Cruise Control improves driver comfort and convenience on long drives.

2. LANE SWAY AND DEPARTURE WARNING

Lane Sway and Departure Warning will alert the driver with a visual and audible warning if the vehicle sways or departs its lane without indicating.

3. LEAD VEHICLE START ALERT

It's easy to become distracted when waiting in stationary traffic. EyeSight will prompt the driver to notice that vehicles in front have started moving again with a buzzer and a flashing indicator.

4. LANE KEEP ASSIST

Lane Keep Assist will offer gentle steering control if the vehicle is about to deviate from its lane at approximately 40 mph or above.

ACCIDENT PREVENTION

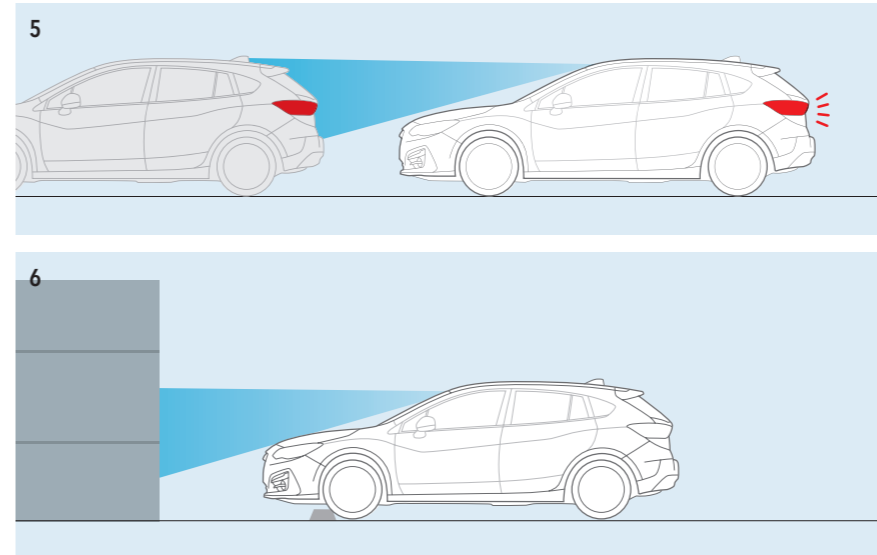

5. PRE-COLLISION BRAKING SYSTEM

Pre-collision Braking System activates visual and audible warnings to alert the driver of a potential collision. If the driver fails to take evasive action, the brakes will be applied automatically to either prevent an accident entirely or reduce the severity of an impact depending on speed. If the driver brakes but does not apply enough pressure, the system will increase braking force.

6. PRE-COLLISION THROTTLE MANAGEMENT

If the car is parked facing an obstacle, EyeSight will give the driver a visual and audible warning if they accidentally select drive instead of reverse. The system will also cut engine output to help avoid a frontal collision.

*EyeSight is a driving support system which may not operate optimally under all driving conditions or for all objects. The driver is always responsible for safe and attentive driving and observance of traffic regulations. See Owner's Manual for complete details on system operation and limitations for EyeSight including functions in this brochure.

Field of vision range from EyeSight (not an actual measurement).



Ice Silver Metallic

Impreza 1.6i SE Lineartronic

DIMENSIONS L x W x H: 4460 x 1775 x 1455 mm
ENGINE Horizontally opposed, 4-cylinder, DOHC
 16-valve petrol direct injection
CAPACITY 1599 cc
MAX OUTPUT 114 PS @ 6,200 rpm
MAX TORQUE 150 Nm @ 3,600 rpm
TRANSMISSION Lineartronic, AWD



Dark Grey Metallic

Impreza 2.0i SE Lineartronic

DIMENSIONS L x W x H: 4460 x 1775 x 1455 mm
ENGINE Horizontally opposed, 4-cylinder, DOHC
 16-valve petrol direct injection
CAPACITY 1995 cc
MAX OUTPUT 156 PS @ 6,000 rpm
MAX TORQUE 196 Nm @ 4,000 rpm
TRANSMISSION Lineartronic, AWD



EXTERIOR COLOURS



Crystal White Pearl

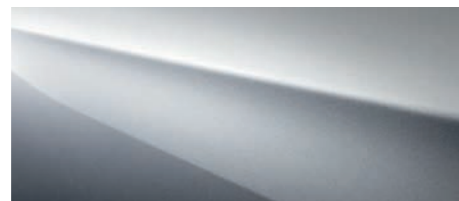

Ice Silver Metallic

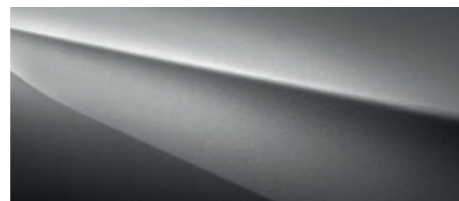

Dark Grey Metallic



Pure Red*

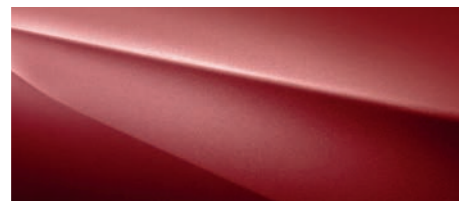

Venetian Red Pearl

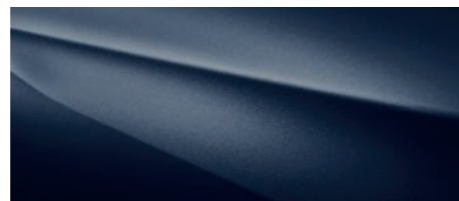

Dark Blue Pearl

SEAT MATERIAL

Black Fabric



Seat Trim



Seat Backing

FEATURES

01 | LED Steering Responsive Headlights

Powered by LEDs, these bi-functional headlights combine low and high beams and are steering-responsive, ensuring good visibility around corners at night.



02 | Power-folding Door Mirrors

Retract both door mirrors in towards the body of the vehicle at the push of a button.



03 | 17" Aluminium-alloy Wheels

The stylish aluminium-alloy wheels are painted black on the inside highlighting their solid, sporty appeal.



04 | LED Rear Combination Lights

The horizontal design of the LED rear combination lights emphasises the wide and sporty exterior look.

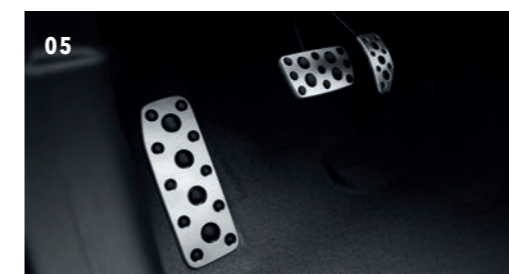

05 | Aluminium Pedals

These motorsports-inspired pedals give the interior an exciting feel.



06 | Keyless Entry and Push-button Start System

With the key fob in your possession, you can unlock the front doors or boot by just gripping the handle and start the engine with the push of a button.



07 | Dual-zone Automatic Air-conditioning System

The air-conditioning system distributes air efficiently for a comfortable cabin in any weather. Both driver and front passenger can independently set their preferred temperature.



08 | Dual USB Ports and Auxiliary Audio Input Jack

Keep all your electronic devices fully charged with easily accessed USB power ports for both front and rear passengers and conveniently play your favourite songs through the audio system with just about any music player.

*Available on Impreza 2.0i SE Lineartronic models only.

PERSONALISE YOUR RIDE.

Whilst every Impreza comes generously equipped, SUBARU accessories are the perfect way to tailor your SUBARU to your life and your style. Whether you want to add convenience, enhance functionality, or personalise your Impreza's appearance, SUBARU accessories are designed to provide the same fit and quality as your SUBARU vehicle. For more details, ask for the accessory brochure or visit your nearest SUBARU retailer.



STI Front Spoiler



Door Visor Set



STI Shift Knob



Front Grille



Body Side Moulding (Carbon Finish)



Carpet Mat



DISCOVER SUBARU

Like to arrange a test drive? After the latest on the SUBARU Impreza or other SUBARU models? Looking for your nearest SUBARU showroom? Simply get in touch...

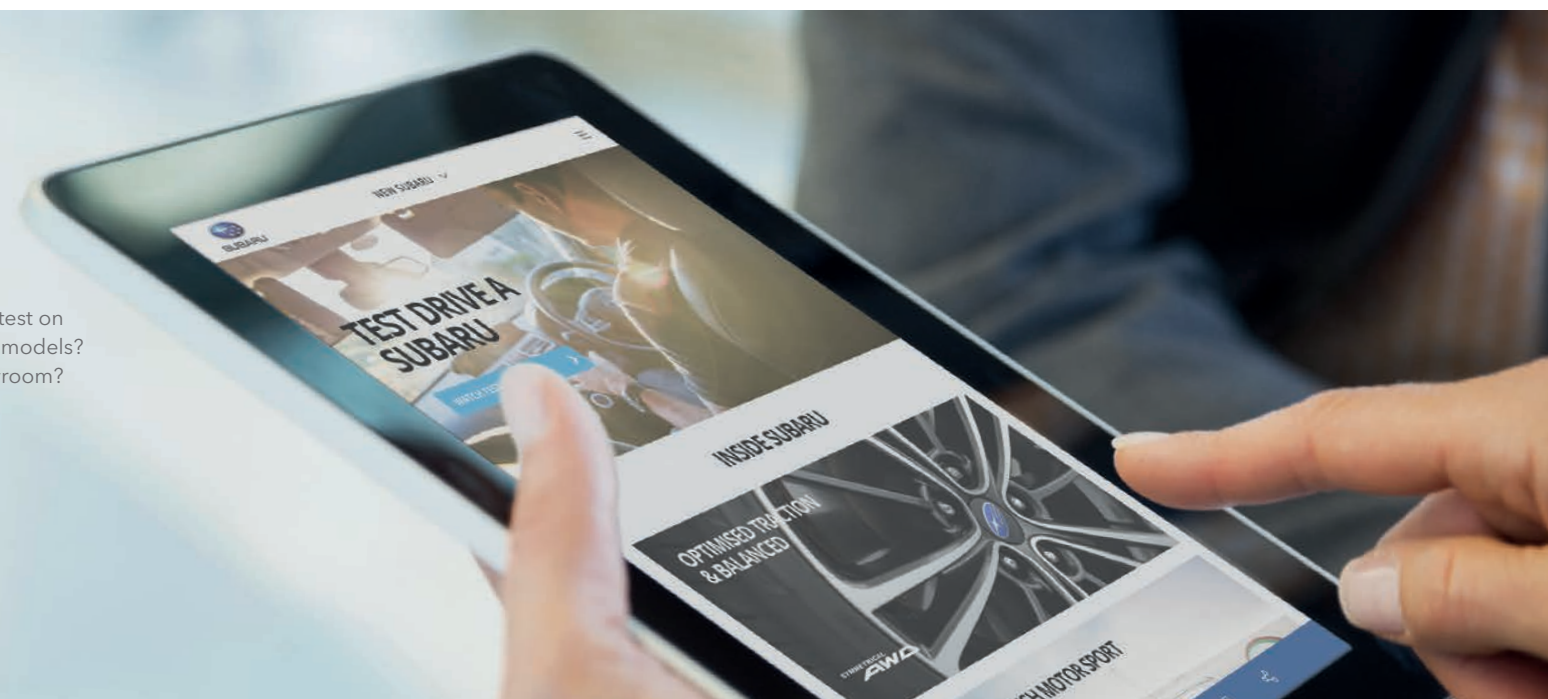

Web Homepage
Visit the SUBARU UK website for the latest information about the SUBARU range.
subaru.co.uk



YouTube
Visit the SUBARU UK website for the latest information about the SUBARU range.
subaru.co.uk



Facebook & Twitter
Stay connected with the SUBARU UK community and be the first to hear the latest news directly from SUBARU.
facebook.com/OfficialSubaruUK
twitter.com/subaruuk

DIMENSIONS

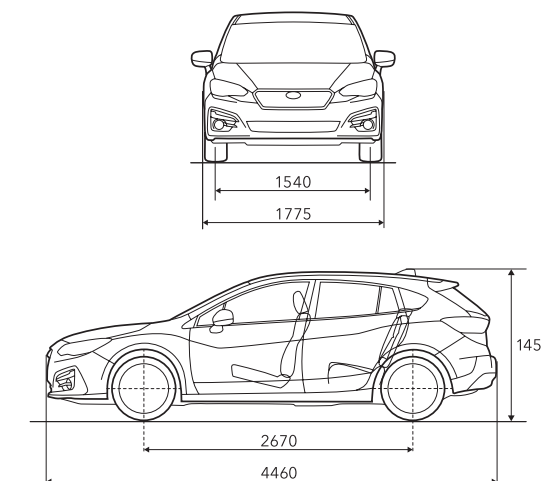

Dimensions are measured in accordance with standard measurement of SUBARU CORPORATION.

Not all features, options, or packages are available for all models and regions. See your specification sheet for availability. Please contact your local authorised SUBARU retailer for more details.

SUBARU CORPORATION reserves the right to alter specifications and equipment without notice. Details of specifications, equipment, colour availability and the accessory lineup are subject to suit local conditions and requirements. Please enquire at your local retailer for details of any changes that might be required for your area.

SPECIFICATIONS

Item	SYMMETRICAL ALL-WHEEL DRIVE		
	1.6i SE LINEARTRONIC		2.0i SE LINEARTRONIC
	CVT		
ENGINE			
Type	Horizontally-opposed, 4-cylinder, 4-stroke, petrol engine		
Valve train	DOHC 16-valve		
Bore/Stroke	mm	78.8 × 82.0	84.0 × 90.0
Capacity	cc	1,599	1,995
Compression ratio		11.0	12.5
Fuel system		Port fuel injection	Direct fuel injection
Fuel tank capacity (approx.)	lit.	50	
PERFORMANCE			
Net Power	PS @ rpm	114 @ 6,200	156 @ 6,000
Torque	Nm @ rpm	150 @ 3,600	196 @ 4,000
Max. speed	mph	112	127
Acceleration (0-62 mph)	sec.	12.4	9.8
Fuel consumption*	Urban	mpg	35.3
	Extra-urban	mpg	51.4
	Combined	mpg	44.1
CO ₂ emissions*	g/km	145	152
Regulation emission standard		Euro 6	
DRIVETRAIN			
All-Wheel Drive type	Active Torque Split AWD system		
DIMENSIONS & WEIGHT			
Overall length	mm	4,460	
Overall width	mm	1,775	
Overall height	mm	1,455	
Wheelbase	mm	2,670	
Track	Front	mm	1,540
	Rear	mm	1,545
Boot volume	lit.	385	
Seating capacity	persons	5	
Kerb weight	kg	1,374	1,379
Towing capacity	kg	1,200	1,200
TRANSMISSION			
Gear ratio	D range	3.601~0.513	
	Reverse	3.687	
Final drive axle ratio		3.900	3.700
CHASSIS			
Steering	Rack and Pinion		
Suspension (4-wheel independent)	Front	MacPherson strut type	
	Rear	Double wishbone type	
Brakes	Front	Ventilated disc brakes	
	Rear	Ventilated disc brakes	
Tyre/wheel size	205/50 R17, 17 x 7" J		

STANDARD FEATURES

Item	SYMMETRICAL ALL-WHEEL DRIVE	
	1.6i SE LINEARTRONIC	2.0i SE LINEARTRONIC
	CVT	
EXTERIOR		
Automatic LED headlights	•	•
Steering responsive headlights	•	•
Front fog lights	•	•
Rear fog lights	•	•
Power-folding door mirrors with built-in LED indicators	•	•
Automatic rain sensing windscreen wipers	•	•
UV protection glass: windscreen, front & rear side windows	•	•
Privacy glass for rear doors, rear quarters and rear windows	•	•
17" alloy wheels	•	•
Roof spoiler	•	•
SEATING & TRIM		
Leather wrapped steering wheel & gearshift knob	•	•
6-way manually adjustable driver's seat	•	•
Heated front seats	•	•
60/40 split folding rear seats	•	•
COMFORT & CONVENIENCE		
Power windows*1	•	•
Remote control central locking	•	•
Keyless entry & push button start system	•	•
Electric parking brake	•	•
Map lights	•	•
Illuminated vanity mirrors (driver & front passenger)	•	•
Centre console box	•	•
Front cup holder (centre console)	•	•
Door pockets with bottle holders (all doors)	•	•
Fuel lid lock release	•	•
Two 12 volt power outlets (instrument panel & centre console box)	•	•
Boot hooks	•	•
Luggage hooks	•	•
Retractable parcel shelf	•	•
Tyre repair kit	•	•
DRIVABILITY		
Vehicle dynamics control system	•	•
Hill assist	•	•
CONTROLS & INSTRUMENTS		
Stop & start system*2	•	•
4.3" LCD multi-information display*3	•	•
Tilt-adjustable / telescopic steering wheel	•	•
Paddle shift	-	•
Cruise control	•	•

*1 Driver's window has auto up/down function with pinch protection.

*2 The stop & start system will automatically stop and restart the engine when the car comes to a standstill to reduce fuel consumption and emissions.

*3 Displays: fuel economy screen, eco-evaluation screen, driving condition, clock with outside temperature and maintenance information etc.

Item	SYMMETRICAL ALL-WHEEL DRIVE	
	1.6i SE LINEARTRONIC	2.0i SE LINEARTRONIC
	CVT	
CLIMATE CONTROL		
Dual-zone automatic air-conditioning system with anti-dust filter	•	•
Windscreen wiper de-icer	•	•
Heated door mirrors	•	•
Heated rear window with timer	•	•
ENTERTAINMENT		
SUBARU infotainment system: 1 CD & 6 speakers	•	•
8" multi-function colour touchscreen	•	•
Apple CarPlay™ & Android Auto™	•	•
DAB radio	•	•
Voice recognition system	•	•
Steering wheel mounted audio & cruise controls	•	•
Bluetooth®	•	•
Dual USB ports & auxiliary audio input jack	•	•
Reversing camera	•	•
SAFETY		
EyeSight*4	•	•
SUBARU rear vehicle detection (SRVD) - includes blind spot monitoring, lane change assist & rear cross traffic alert	•	•
High beam assist (HBA)	•	•
Front SRS*5 airbags	•	•
Front side SRS*5 airbags (driver & front passenger)	•	•
Curtain SRS*5 airbags	•	•
Knee SRS*5 airbags	•	•
Daytime running lights	•	•
Tyre pressure monitoring system	•	•
Side door reinforcement beams	•	•
Steering column support beam	•	•
Rear seat headrests for 3 seating positions	•	•
Whiplash reducing front seats	•	•
Seatbelt indicator (driver & all passengers)	•	•
Height adjustable front seatbelts with pretensioners & load limiters	•	•
Rear 3-point seatbelts for 3 seating positions	•	•
Safety pedal system	•	•
Anti-lock braking system (ABS) with electronic brake force distribution (EBFD)	•	•
Brake assist system	•	•
Brake override	•	•
ISOFIX adapted child seat anchors (with tether anchors)	•	•
Child-proof rear door locking	•	•
Anti-theft security system with engine immobiliser	•	•

*4 EyeSight includes: adaptive cruise control, pre-collision braking, pre-collision throttle management, lane sway and departure warning, lane keep assist and lead vehicle start alert.

*5 SRS: Supplemental Restraint System. Must be used in conjunction with seatbelts.



† The service intervals for the SUBARU Impreza are every 12 months/12,000 miles, whichever comes sooner. The SUBARU Impreza is covered by a 5 Year/100,000 miles (whichever is sooner) Limited Warranty. This comprises of a standard 3 Year/60,000 miles (whichever is sooner) Manufacturer's Warranty (bumper to bumper, excluding clutch driven plate) and an Extended Warranty that applies to the powertrain only, provided by the importer, to complete the 5 Year/100,000 miles (whichever is sooner) Limited Warranty. All vehicle bodywork is covered by a 12 Year Anti-Corrosion Warranty and paintwork is covered by a 3 Year/60,000 miles (whichever is sooner) Warranty. Added reassurance is provided by a comprehensive 3 Year Recovery and Assistance Programme valid in the UK only. For general terms and conditions visit SUBARU.co.uk.

Technical data and equipment based on the latest information available at the time of printing. SUBARU (UK) Ltd reserves the right to make changes at any time, without notice, in colours, materials, design, prices, equipment and specifications and to discontinue models. Customers are advised to consult their SUBARU dealer on the precise details of warranties/guarantees and vehicles available for sale. Models specified are strictly subject to availability. Owing to the limitations of printing processes, the colours reproduced may not exactly match product colours. The contents of this brochure are the copyright of SUBARU (UK) Ltd and may not be copied or displayed for commercial purposes without the express permission of SUBARU (UK) Ltd. © SUBARU (UK) Ltd. E & O.E.

SUBARU (UK) Ltd.

For details of your nearest SUBARU dealer phone 03303 335117 or visit SUBARU.co.uk.

Calls (to 03 numbers) cost no more than calls to geographic numbers (01 or 02) and must be included in inclusive minutes and discount schemes in the same way. Calls from landlines are typically charged up to 9p per minute; calls from mobiles typically cost between 3p and 40p per minute. Calls from landlines and mobiles are included in free call packages.

5 YEAR
WARRANTY†

18MY SIB185