



SunnCamp 2019



## INTRODUCTION

For over 30 years SunnCamp has been manufacturing outdoor products including Caravan Awnings, Motor Awnings, Trailer Tents and Tents. Our aim is to produce the best range of meticulously designed, exceptionally well-made and fantastic value products that will give you and your family the best outdoor experience. All our products are made from specially developed fabrics and have a vast range of features and attention to detail.

## CONTENTS

Page 2	<b>Introduction</b>
Page 3	<b>SunnCamp Fabrics</b>
Page 4	<b>Air Volution – Pole Free Inflatable Pitching</b>
Page 5	<b>Specifications</b>
Page 6-7	<b>Enhance your SunnCamp Experience</b>
Page 8-11	<b>Icon Air/Esteemed Air – Full Touring Awnings</b>
Page 12-20	<b>SunnCamp Air Volution Porch Awnings</b>
Page 21-27	<b>SunnCamp Poles Porch Awnings/Sun Canopies</b>
Page 28	<b>SunnCamp Air Volution Motor Awnings</b>
Page 29-35	<b>SunnCamp Poles Motor Awnings</b>
Page 36-38	<b>SunnCamp Tents, Utility Tents, Extensions, Windbreaks</b>
Page 39	<b>Glossary</b>





## FABRICS

All SunnCamp fabrics comply with the latest British Standard Flame Retardant Regulations

### SunnCamp's ACE-TECH Fabric



Our **ACE-TECH** fabric comes in various weights and is coated with layers of a specific mix of PU waterproof coating which has been evenly and uniquely applied so that the fabric offers protection from the elements and UV light.

### SunnCamp's PRO-TEK 300D Fabric



A super strength 300 denier high density fabric which has been developed by SunnCamp's technical team.

**PRO-TEK 300D** offers four times the tensile strength as standard 75D fabric and new improvements and technical developments have allowed our fabric to be specially woven and coated with layers of waterproof coating which have been evenly and uniquely applied so that the fabric keeps its ultra flexibility and softness, yet sits suitably in shape. **PRO-TEK 300D's** high tensile strength offers increased protection from the elements.

Our **PRO-TEK 300D ERP** (Enhanced Roof Profile) roof fabric further complements the appearance of our products and provides a homely ambience.

### 150D Oxford/150D Oxford Ripstop Fabric



A high quality fabric (twice as thick as regular flysheets) providing improved protection from the weather and UV light. Our ripstop version has the same specification but has been woven using a special reinforcing technique where reinforcement threads are woven at regular intervals in a crosshatch pattern making the fabric more resistant to tearing.



## AIR VOLUTION – POLE FREE INFLATABLE PITCHING

In place of conventional poles, SunnCamp's Air Volution products are pre-fitted with durable air tubes which are enclosed in a heavy duty double layer sleeve, providing an extremely secure and stable structure when inflated and guyed.

### Setting up is easy...

Attach the inflator pump to the valves in the air tubes and pump until you reach the correct pressure of 7 psi. Close the valves and your product is ready for use. Air tubes should be inflated to 7 psi.

We utilize two inflation systems within our range of products. Please check individual entries for clarification.

- Single Inflation – this system allows all beams to be inflated at one time from one inflation point.
- Multi Inflation – this system allows each section to be inflated separately from multiple inflation points.

### Air Volution Advantages

- Quick, simple and effortless pitching and take down
- Robust maintenance free inflatable tubes replace conventional poles
- Products can in most cases easily be erected by one person





# SPECIFICATIONS

## Standard Specification

- Waterproof and Fire Retardant flysheet
- Taped Seams
- Heavy duty zips
- Curtains on all windows
- Colour coded poles and sleeves (where applicable)
- Pre-attached guy lines
- Pegs for main pegging points

## Full Awning Specification

- Single inflation
- 300D Protek Fabric/300D Enhanced Roof Fabric
- Multi-zip curtain system
- LED Light pockets in roof bars
- Pre-attached storm buckles and webbing straps
- Hand pump with gauge and dump valve
- Draught skirt with ventilation panels

## Porch Awning Specification

- Check entry for clarification of single or multi point inflation (Air Volution products)
- See awning entry for fabric specification
- Rear pads: Rear pads to seal to caravans (except Swift Canopy/Protekta/SunnShield)
- Hand pump with gauge and dump valve (Air Volution models only)
- Draught skirt (except Swift Canopy/Protekta/Sunnshield)

## Motor Awning Specification

- See awning entry for fabric specification
- Cable entry point and tidy system—see entry for details
- Hand pump with gauge and dump valve (Air Volution models only)
- Figure of 8 Fixing Kit

## Tent Specification

- See tent entry for fabric specification
- Daylight panel
- Twilight inner tents
- Cable entry point and tidy system
- Hand pump with gauge and dump valve (Air Volution models only)



## LED LIGHTING SYSTEM Starter Pack (EL3001)

**Ideal for: Inflatable or Poled Awnings, Motor Awnings & Tents**

### Includes:

- 2 x 1m LED light strips with magnets and tie cables
- 1 x 5m cable/1 x 3m cable/1 x 60cm cable/1 x 30cm cable
- 1 x remote control (with in line sensor)
- 1 x UK Plug (approx. 1m cable)
- 1 x 12V cigarette socket (approx. 3m cable)



## LED LIGHTING SYSTEM Add on Kit (EL3002)

**Ideal for: Inflatable or Poled Awnings, Motor Awnings & Tents**

### Includes:

- 1 x 1m LED light strip with magnets and tie cables
- 1 x 3m cable
- 1 x 60cm cable
- 1 x 30cm cable



**Illuminate  
your  
Awning/Tent**

## LED LIGHT SLEEVES (DT0101)

**Suitable for all SunnCamp Air Volution models (dual inflation)**

### Pack comprises of 2 sleeves

- Recommended for use with: SunnCamp LED Lighting System (EL3001) & Add on Kit (EL3002)
- Sleeves Velcro onto inflatable storm bars
- LED Lights easily insert into sleeves via zipped PVC section
- Sleeve length 1 metre (approx.)



## 12V ELECTRIC PUMP (AC3000)

**Suitable for all SunnCamp Air Volution models**

**Ideal for all  
Air Awnings  
and Air Tents**

- Powered by car 12V socket
- Can inflate up to 16 psi
- Cuts out at pre-set pressure
- Extra long 10m cable
- Two nozzle fittings





## STORM BAR KITS

Storm Bar Kits to complement your awning are available for various Air Volution models.

Please ask your stockist for further information or email [info@sunncamp.co.uk](mailto:info@sunncamp.co.uk)



## ROOF LININGS

Roof Linings are available for some models. Please ask your stockist for further information or email [info@sunncamp.co.uk](mailto:info@sunncamp.co.uk)



## AWNING SEAL SET [AC71003]

Ideal for use with Porch Awnings

- Inflatable pads help seal awning to caravan
- Prevents draughts
- Improves fit of awning
- Reduces movement of awning

Improve the seal of awning to caravan



Internal



External

## ALSO AVAILABLE:

- **Bespoke Breathable Groundsheets**
- **Bespoke Luxury Carpets**
- **Rear Poles**
- **Canopy Poles**
- **Storm Poles**
- **Wheel Arch Covers**

Ask your dealer for further information or contact SunnCamp direct on [info@sunncamp.co.uk](mailto:info@sunncamp.co.uk)

# ICON AIR® FULL TOURING AWNING

Maximum living space

Single inflation



ICON AIR - model shown size 11

Simple and effortless pitching and inflation

### Available Sizes:

Size 11 (SI 1011)	Size 12 (SI 1012)	Size 13 (SI 1013)	Size 14 (SI 1014)	Size 15 (SI 1015)	Size 16 (SI 1016)	Size 17 (SI 1017)	Size 18 (SI 1018)
900 – 925cm	925 – 950cm	950 – 975cm	975 – 1000cm	1000 – 1025cm	1025 – 1050cm	1050 – 1075cm	1075 – 1100cm

### Layout:

Size: 900-975cm (Size 11-13)

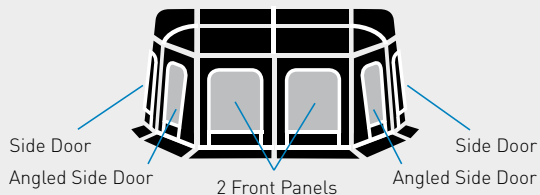

Size: 975-1100cm (Size 14-18)

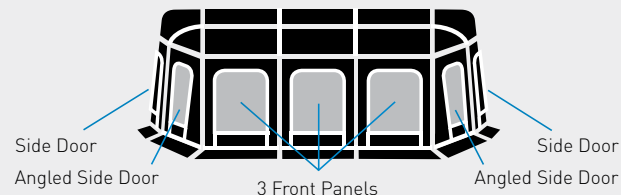

The Icon Air has been designed as a Full Touring Awning, however we do not recommend it be sited for permanent use. We also advise, due to their nature, against siting on permanent style pitches as damage can be caused through natural contact and friction to the base materials of the awning.

**If you require guidance on the correct size awning for your caravan, please contact your SunnCamp Dealer/Stockist.**

ICON AIR® Full Awning Size 17 – Approximate weight 30kg including all zip out panels. We recommend you remove these before feeding awning through your caravan rail.

ICON AIR ANNEXE Approximate weight 7.5kg

- Includes** Pump with gauge and dump valve
- Includes** Storm Buckles & Straps
- Includes** Veranda Pole
- Includes** Draught Skirt
- Includes** AIR Flow Zip In/Out Ventilation Panels



Add space with our optional **ICON AIR ANNEXE (SI1000)**



ICON AIR - model shown size 17



Internal view

Innovative design, quality construction ...

**Floor Plan - showing Optional Annexe**

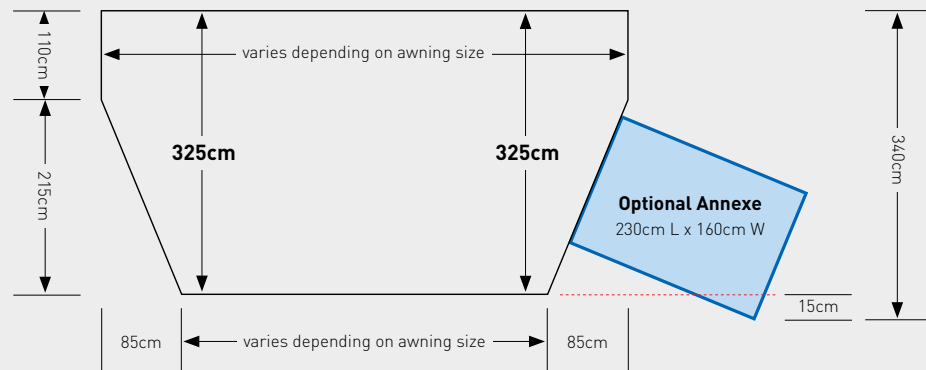

**Features:**

- Air Volution Single Inflation
- Secondary mesh on side doors
- Zip in mesh panels for all other panels
- LED light pockets (for optional LED light system)
- Removable panels (all with veranda option) dependant on size (900 – 975cm = 4 panels, 975 – 1100cm = 5 panels)
- Multi-zip curtains on all windows
- External peggable mud wall for extra weather protection (PVC mesh)
- Draught skirt with ventilation panels
- Pre-attached storm buckles and webbing straps
- Pre-attached guylines



# ESTEEMED AIR FULL TOURING AWNING

Compatible with **ESTEEMED AIR ANNEXE** (SI1000)

## Features:

- Air Volution Single Inflation
- Removable interchangeable side panels with secondary mesh
- LED Light Pockets (for optional LED light system)
- Removable panels with veranda option
- Multi-zip curtains on all windows
- External peggable mud wall for extra weather protection (PVC mesh)
- Draught skirt with ventilation panels
- Pre-attached storm buckles and webbing straps
- Pre-attached guy lines

Single inflation

Maximum living space

## Available Sizes:

Size 8 (SE1008)	Size 9 (SE1009)	Size 10 (SE1010)	Size 11 (SE1011)
825 – 850cm	850 – 875cm	875 – 900cm	900 – 925cm
Size 12 (SE1012)	Size 13 (SE1013)	Size 14 (SE1014)	Size 15 (SE1015)
925 – 950cm	950 – 975cm	975 – 1000cm	1000 – 1025cm
Size 16 (SE1016)	Size 17 (SE1017)	Size 18 (SE1018)	
1025 – 1050cm	1050 – 1075cm	1075 – 1100cm	

Our new EsteemedAIR full touring, single inflation awning, with similar features to our IconAIR full awning but with a new depth of 250cm. Multi-zip curtains, removable roll down panels and LED pockets for use with SunnCamp's optional LED light system. A left or right fit annexe is also available, ensuring you have all the attributes required for a perfect holiday.

## Floor Plan - showing Optional Annexe

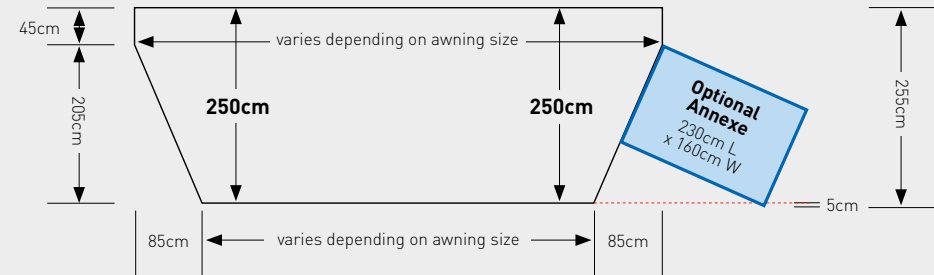

## Layout:

Size: 825-975cm **(Size 8-13)**

Size: 975-1100cm **(Size 14-18)**

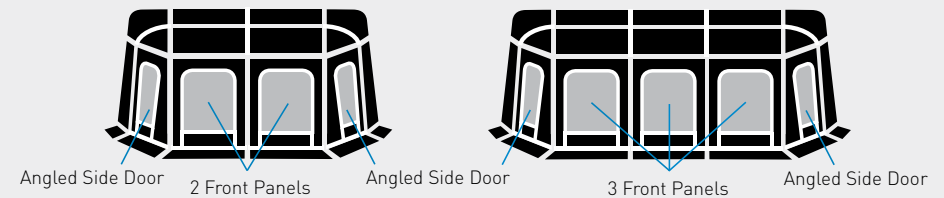

If you require guidance on the correct size awning for your caravan, please contact your SunnCamp Dealer/Stockist.

Includes Pump with gauge and dump valve

Includes Draught Skirt

Includes Storm Buckles & Straps

Includes Veranda Pole





... effortless  
comfort with  
unsurpassed  
quality and  
features



**ESTEEMED AIR size 14 closed curtains**



**Optional LED Light System**



**AIR VOLUTION single Inflation System**

Add extra  
space with  
our optional  
**ESTEEMED  
AIR ANNEXE  
(SI 1000)**

**ESTEEMED AIR size 14 with optional annexe**

# INCEPTOR AIR EXTREME 390 (SF1900)

# INCEPTOR AIR EXTREME 330 (SF1901)

Compatible with AIR ANNEXE PLUS (SF7813)

Compatible with APARTAIR (SF8008-R/SF8008-L)

Single inflation

### Features:

- Air Volution Single Inflation
- Compatible with Air Annexe Plus – will fit onto either side of awning
- Compatible with ApartAIR – left and right fit available
- Interchangeable, removable side panels with secondary mesh
- Removable front panels
- Two zip in/out airflow panels (1 x front right/1 x front left)
- Veranda option on all panels
- LED light pockets (for optional LED light system)
- SunnCamp's enhanced roof profile (ERP)
- Window lights in roof (with curtains)
- Curtains on all windows/Multi-zip curtains on front windows
- External peggable mud wall for extra weather protection (PVC mesh)
- Vertical storm pole pockets
- Draught Skirt with ventilation panels
- **Height range: 235cm – 250cm**

See page 20 for available accessories to complement your awning

	390	330	Annexe	ApartAIR
<b>Approx. Pack Size:</b>	79cm x 43cm	79cm x 42cm	65cm x 25cm	72cm x 28cm
<b>Approx. Weight:</b>	30kg	26kg	7.5kg	12kg

Presenting our all new Air Volution Single Inflation Inceptor Air Extreme 390 and 330 porch awnings. Upgraded with new features including single inflation and multi-zip curtains, whilst retaining features from prior year models including its 325 depth, stunning panoramic views, removable panel/vent options and compatibility with our exciting new left or right fit ApartAIR rooms.

### Floor Plans

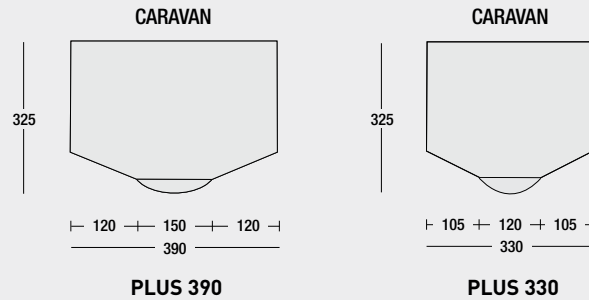

- Includes Pump with gauge and dump valve
- Includes AIR Storm Bars **x6**
- Includes Rear Weather Poles
- Includes Storm Buckles & Straps
- Includes Veranda Pole
- Includes Vertical Storm Pole **x1**
- Includes Draught Skirt
- Includes AIR Flow Zip In/Out Ventilation Panels **x2**

**AIR ANNEXE PLUS (SF7813) WITH REAR ZIP ACCESS**

Breathable Annexe Groundsheet Available: DT0066

Includes Twilight Inner Tent

**APARTAIR LEFT HAND FIT (SF8008L) & RIGHT HAND FIT (SF8008R) AVAILABLE**

Breathable Groundsheet Available: DT0037

Luxury Carpet Available: BC1004





INCEPTOR AIR EXTREME 390



INCEPTOR AIR EXTREME 330

... panoramic views from the inside and its superb appearance from the outside...



Internal view



APARTAIR right fit

# ULTIMA AIR EXTREME 390 (SF1902)

# ULTIMA AIR EXTREME 280 (SF1940)

Compatible with **ULTIMA AIR ANNEXE (SF7862)** will fit either side of awning

### Features:

- Air Volution Single Inflation
- Ultima Air Extreme 390/280 Compatible with Ultima Air Annexe – will fit onto either side of awning
- Interchangeable, removable side panels with secondary mesh
- LED light pockets (for optional LED light system)
- Roll up front panels with canopy option
- Veranda option available on side panels
- SunnCamp's enhanced roof profile (ERP)
- Curtains on all windows/Multi-zip curtains on front panels
- External peggable mud wall for extra weather protection (PVC mesh)
- Vertical storm pole pockets
- Optional extra zip on front canopy (available for all models)
- **Height range: 235cm – 250cm**

Single inflation

	Extreme 390	Extreme 280	Annexe
<b>Approx. Pack size:</b>	79cm x 37cm	79cm x 33cm	76cm x 21cm
<b>Approx. Weight:</b>	28kg	24kg	10kg
<b>Air Storm Bars</b>	x 6	x 4	N/A
<b>Veranda Pole</b>	optional	optional	N/A

Extreme in name, performance and features our ULTIMA AIR EXTREME 390/280 made in our 300D Protek fabric with 6000mm HH. Features include our multi-style zip curtains and our 300D Enhanced Roof Profile fabric.

### Floor Plans

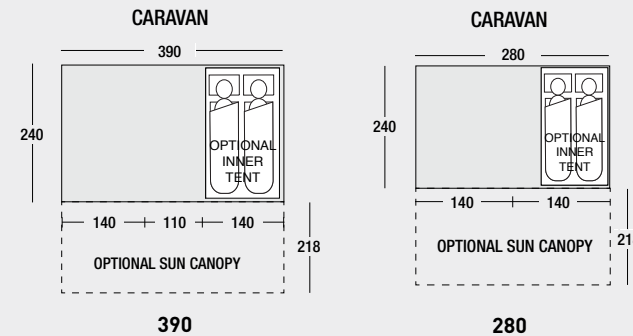

See page 26 for details of optional sun canopy

Optional Inner Tent Available (SF9600)

- Includes Pump with gauge and dump valve
- Includes AIR Storm Bars
- Includes Rear Weather Poles
- Includes Storm Buckles & Straps
- Includes Draught Skirt

**ULTIMA AIR ANNEXE SUPER DELUXE (SF7862) WITH REAR ZIP ACCESS**

Breathable Annexe Groundsheet Available: DT0066

- Includes Twilight Inner Tent





**ULTIMA AIR EXTREME 390**



Internal views



Utilize SunnCamp's LED Lighting System to illuminate your awning



**ULTIMA AIR EXTREME 390** with optional canopy



**ULTIMA AIR EXTREME 390** shown with optional annexe



**SWIFT AIR 390** (SF7817)

**SWIFT AIR 325** (SF7763)

**SWIFT AIR 260** (SF7764)

**SWIFT AIR 220** (SF7809)

Compatible with **TWO BERTH INNER TENT** (SF1905)

**Features:**

- Roll up front door with canopy option (Poles optional extra)
- Curtains on all windows
- Air flow side doorways
- Centre pocket for optional roof pole
- Vertical storm pole pocket (390 model only)
- **Height Range: 235 - 250cm**

	390	325	260	220
<b>Approx. Pack size:</b>	79cm x 32.5cm	69cm x 31cm	65cm x 30cm	64cm x 29cm
<b>Approx. Weight:</b>	13kg	11kg	10kg	8kg
<b>Air Storm Bars</b>	x 3	x 1	optional	optional

Easy to erect, stylish and fantastic value for money, our Swift Air is available in four sizes.

All models have air flow side doorways and a roll up front door with canopy option.

Optional  
2 Berth  
Inner Tent  
Available  
(SF1905)

Complement  
your awning  
with our  
luxury carpet



**Floor Plans**

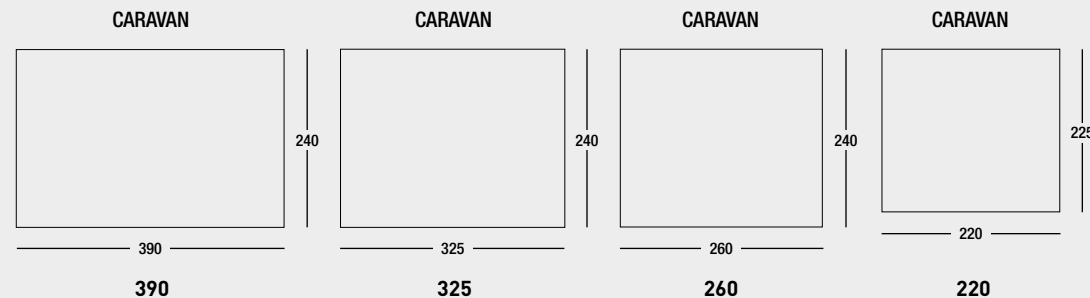

**Includes Pump**  
with gauge and dump valve

**Includes Storm Buckles & Straps**

**Includes AIR Storm Bars** x3 390

**Includes Vertical Storm Pole** 390

**Includes AIR Storm Bars** x1 325

**Includes Draught Skirt**

See  
page 20  
for details of  
optional  
extras



SWIFT AIR 220

Easy to erect,  
stylish and  
fantastic  
value for  
money ...



SWIFT AIR 390



Internal view



SWIFT AIR 325



SWIFT AIR 390



SWIFT AIR 260 AIR shown  
with optional two berth inner tent



Optional  
2 Berth  
Inner Tent  
Available  
(SF7024)

**ULTIMA VERSARA AIR 390** (GREY-SF1903/BLUE-SF1931)

**ULTIMA VERSARA AIR 300** (GREY-SF1930/BLUE-SF1932)

**ULTIMA VERSARA AIR 200** (GREY-SF1904/BLUE-SF1933)

Compatible with **ULTIMA VERSARA POLED ANNEXE** (SF1913)



ULTIMA VERSARA AIR 390 - Blue

Available  
in Grey  
or Blue  
colourway

**Features:**

- Optional POLED annexe available (SF1913)
- Roll up front panels with canopy option (Poles optional extra)
- Removable side (right) panel with secondary mesh and veranda option
- Left airflow side doorway
- Curtains on all windows
- Vertical storm pole pockets
- Optional inner tent available (SF7024)
- Includes AIR storm bars (390x3/300x2/200x1)
- **Height Range: 235 - 250cm**

**Floor Plans**

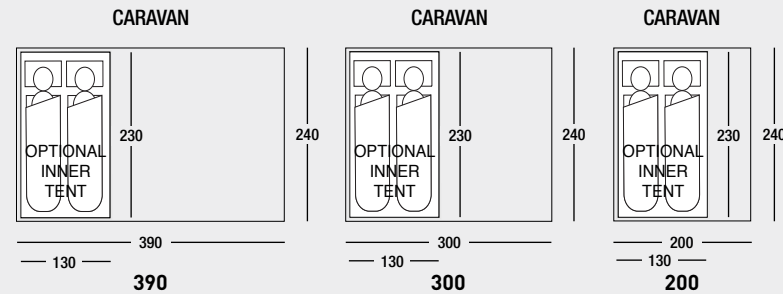

	390	300	200	Annexe
<b>Approx. Pack size:</b>	78cm x 32cm	78cm x 31cm	78cm x 29cm	69cm x 22cm
<b>Approx. Weight:</b>	15kg	12kg	10kg	7.5kg
<b>Roof Poles</b>	x 3	optional	optional	N/A

Includes Pump with gauge and dump valve

Includes AIR Storm Bars

Includes Storm Buckles & Straps

Includes Draught Skirt

**ULTIMA VERSARA POLED ANNEXE (SF1913)**

Breathable Annexe Groundsheet Available: DT0066

Includes Twilight Inner Tent





ULTIMA VERSARA AIR 300 - Grey

Available in Grey or Blue colourway



ULTIMA VERSARA AIR 200 - Grey

## DASH AIR 260 (SF7820)

## DASH AIR 220 (SF7893)

Optional 2 Berth Inner Tent Available (SF1905)

### Features:

- Roll up front door with canopy option (Poles optional extra)
- Curtains on all windows
- Centre pocket for optional roof pole
- **Height Range: 235 - 250cm**
- **260 Pack Size: 64 x 29cm/Weight 9.6kg approx.**
- **220 Pack Size: 63 x 28cm/Weight 7.6kg approx.**

Includes Pump with gauge and dump valve

Includes Storm Buckles & Straps

Includes Draught Skirt

Our Dash Air awning is manufactured in our **75D ACE-TECH** fabric, incorporates our proven Air Volution technology with a front panel that can be rolled up or used as a canopy when utilized with our optional canopy pole set.

### Floor Plans

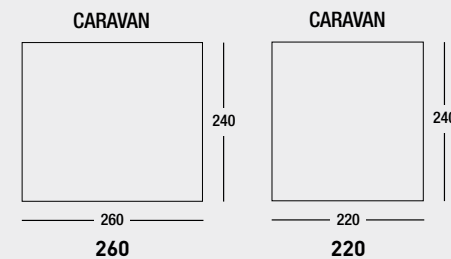

DASH AIR 260



12V Pump available  
See page 6

## OPTIONAL EXTRAS - Air Volution Awnings

Model	Luxury Awning Carpet	Breathable Groundsheet	Rear Poles	Veranda Pole	Additional Air Storm Bars	Additional Alu Roof Pole	Canopy Pole Set	Annexe	Vertical Storm Pole	Inner Tent	Roof Lining	Sun Canopy	Awning Windbreak
Icon Air	YES*	N/A	N/A	DT0091	N/A	N/A	N/A	SI1000	DT0052	N/A	N/A	N/A	N/A
Esteemed Air	YES*	N/A	N/A	DT0091	N/A	N/A	N/A	SI1000	DT0052	N/A	N/A	N/A	N/A
Icon/Esteemed Air Annexe	N/A	DT0066	N/A	N/A	N/A	N/A	DT0032	N/A	N/A	N/A	N/A	N/A	N/A
Inceptor Air Extreme 390	BC1010	DT0055	✓ Included	✓ Included	SF7787 (x3)	N/A	N/A	SF7813	DT0052	N/A	SF4002	N/A	SF7838
Inceptor Air Extreme 330	BC1012	DT0061	✓ Included	✓ Included	N/A	N/A	N/A	SF7813	DT0052	N/A	SF4003	N/A	SF7838
Ultima Air Extreme 390	BC1008	DT0038	✓ Included	DT0091	N/A	N/A	DT0032	SF7862	DT0052	SF9600	SF4005	SF8003	SF7838
Ultima Air Extreme 280	BC1005	DT0042	✓ Included	DT0091	N/A	N/A	DT0032	SF7862	DT0052	SF9600	SF4006	SF8002	SF7838
Swift Air 390	BC1008	DT0038	DT0052	N/A	SF7789 (x2)	DT0091-B	DT0032	N/A	DT0052	SF1905	N/A	N/A	SF7838
Swift Air 325	BC1006	DT0053	DT0052	N/A	SF7788 (x2)	DT0091-B	DT0032	N/A	N/A	SF1905	N/A	N/A	SF7838
Swift Air 260	BC1004	DT0037	DT0052	N/A	SF7786 (x2)	DT0091	DT0032	N/A	N/A	SF1905	N/A	N/A	SF7838
Swift Air 220	BC1003	DT0046	DT0052	N/A	SF7785 (x2)	DT0091	DT0032	N/A	N/A	SF1905	N/A	N/A	SF7838
Ultima Versara Air 390	BC1008	DT0038	DT0052	DT0091	SF7847 (x3)	N/A	DT0032	SF1913	N/A	SF7024	N/A	N/A	SF7838
Ultima Versara Air 300	BC1017	DT0059	DT0052	DT0091	SF9400 (x2)	N/A	DT0032	SF1913	N/A	SF7024	N/A	N/A	SF7838
Ultima Versara Air 200	BC1027	DT0102	DT0052	DT0091	SF7900 (x1)	N/A	DT0032	SF1913	N/A	SF7024	N/A	N/A	SF7838
Dash Air 260	BC1004	DT0037	DT0052	N/A	SF7786 (x2)	DT0091	DT0032	N/A	N/A	SF1905	N/A	N/A	SF7838
Dash Air 220	BC1003	DT0046	DT0052	N/A	SF7785 (x2)	DT0091	DT0032	N/A	N/A	SF1905	N/A	N/A	SF7838

\* Contact your dealer or email SunnCAMP on info@sunnecamp.co.uk

... enhanced headroom and living space

**ULTIMA CLASSIC 390** [SF7828]

**ULTIMA VERSARA 390** [SF1911] **ANNEXE Compatible** [SF1913]

**ULTIMA CLASSIC 260** [SF7829]

**ULTIMA VERSARA 260** [SF1912] **ANNEXE Compatible** [SF1913]

**Features:**

**ULTIMA VERSARA 390/260 AND ULTIMA CLASSIC 390/260**

- **Height Range: 235-250cm**
- Roll up panels with canopy option (Poles optional extra)
- Curtains on all windows
- Sleeps two with optional inner tent (SF7024)
- Steel and fibreglass frame

Optional  
2 Berth  
Inner Tent  
Available  
[SF7024]

Check out  
optional extras  
available on  
page 27

**ULTIMA VERSARA 390/260**

- Removable side (right) panel with secondary mesh and veranda option
- Optional annexe available [SF1913]
- Airflow left side doorway

**ULTIMA CLASSIC 390/260**

- Two side airflow doorways

	390	260	Annexe
<b>Approx. Pack size:</b>	76cm x 30cm	76cm x 28cm	69cm x 20cm
<b>Approx. Weight:</b>	21kg	18kg	6kg



ULTIMA CLASSIC 260



ULTIMA VERSARA 390 with optional annexe

Our much-loved Ultima models in SunnCamp's original profile/shape with enhanced headroom and living space. Our ULTIMA VERSARA 390 and 260 models are compatible with our VERSARA ANNEXE and fit on the right side of the awning.

**Floor Plans**

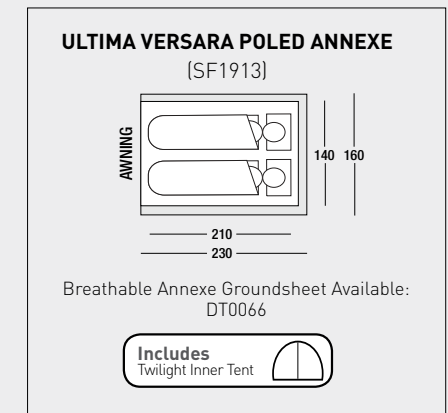
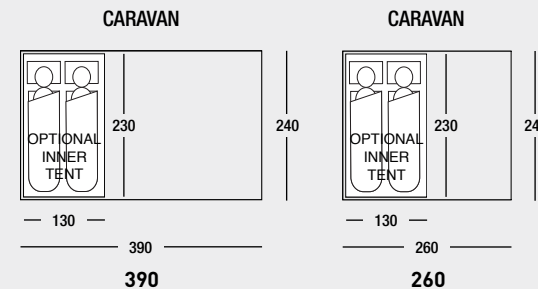

Includes Internal Roof bars **x2**

Includes Storm Buckles & Straps

Includes Draught Skirt

Breathable Annexe Groundsheet Available: DT0066

Includes Twilight Inner Tent



**SWIFT DELUXE 390** (LIGHT GREY -SF7831/DARK GREY-SF1906)

**SWIFT DELUXE 325** (LIGHT GREY-SF7769/DARK GREY-SF1907)

**SWIFT DELUXE 260** (LIGHT GREY-SF7803/DARK GREY-SF1908/BLUE-SF7845)

**SWIFT DELUXE 220** (LIGHT GREY-SF7802/DARK GREY-SF1910/BLUE-SF7844)

Optional  
2 Berth  
Inner Tent  
Available  
(SF1905)

**Features:**

- Front door with canopy option (Poles optional extra)
- Curtains on all windows
- Two side doorways (390 and 325 only with airflow doorways)
- Centre pocket for optional roof pole
- Steel and fibreglass frame
- **Height Range: 235 - 250cm**

Breathable  
groundsheets &  
luxury carpets  
available for all  
porch awnings

	390	325	260	220
<b>Approx. Pack size:</b>	79cm x 26cm	79cm x 24cm	78cm x 22cm	78cm x 21cm
<b>Approx. Weight:</b>	11.5kg	7.7kg	6.8kg	6.3kg
<b>Alu Roof Poles</b>	x 3	optional	optional	optional

Simple, practical, reliable and stylish, our illustrious range of SWIFT DELUXE AWNINGS come in a variety of sizes.

All sizes are available in our light grey/black colourway and dark grey/black colourway. Our 220 and 260 models are also available in our blue/grey colourway.



SWIFT DELUXE 325 - Dark Grey

**Floor Plans**

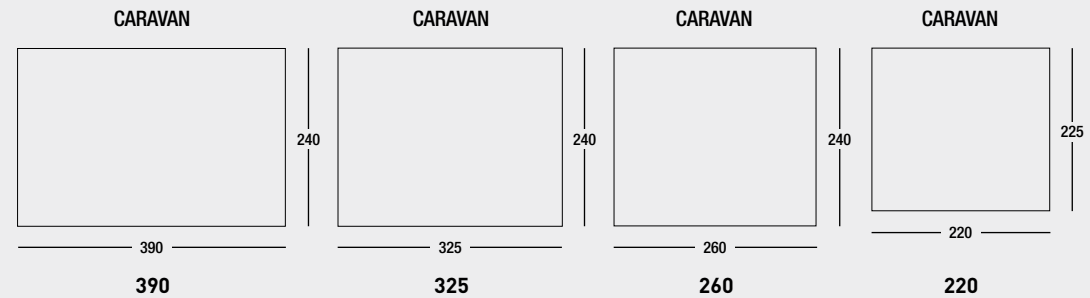

Includes  
Roof Poles  
**x3**  
390

Includes  
Draught Skirt  
220

SWIFT DELUXE 260 - Blue



SWIFT DELUXE 390 - Dark Grey



SWIFT DELUXE 325 - Dark Grey



Simple, practical, reliable and stylish ...

SWIFT DELUXE 260 - Light Grey



SWIFT DELUXE 325 - Dark Grey



SWIFT DELUXE 390 shown with optional two berth inner tent





**SWIFT CANOPY 390** (SF8000)  
**SWIFT CANOPY 330** (SF8004)  
**SWIFT CANOPY 260** (SF7690)  
**SWIFT CANOPY 200** (SF1914)

Check out optional extras available on page 27

**Features:**

- Steel and fibreglass frame
- Side windows
- **Height Range 235cm-250cm**

	390	330	260	200
<b>Approx. Pack size:</b>	79cm x 18cm	77cm x 15cm	76cm x 17cm	75cm x 15cm
<b>Approx. Weight:</b>	7kg	5kg	6.4kg	5kg
<b>Alu Roof Poles:</b>	x 1	✗	✗	✗

The perfect sun canopy - stylish and easy to set up! Now available in four sizes; 390, 330, 260 and 200.

**Floor Plans**

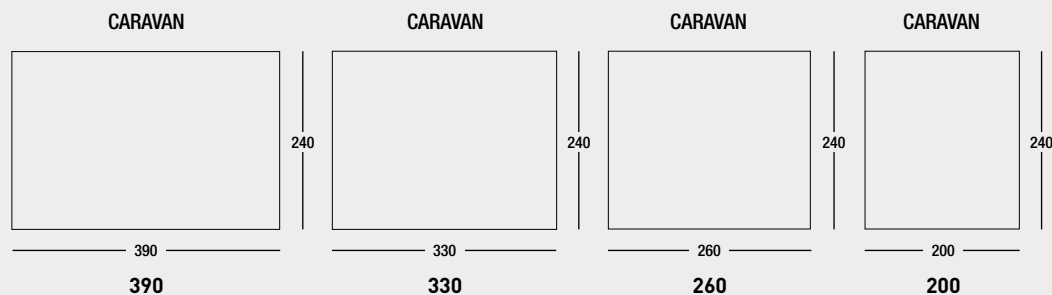

SWIFT CANOPY 390

... stylish and easy to set up!



SWIFT CANOPY 200



## PROTEKTA - ROLL OUT SUN CANOPY

### Features:

- Minimum front height approximately 190cm
- Approximate projection 218cm
- Front leg adjustable heights: 192cm/204.5cm/217cm/229.5cm
- Aluminium frame

### Optional Extras

Roof support/leg pole (DT0092)

7' Front Wall and 2 x Side Wall fits 192cm/204.5cm height (SF7832)

7' Front Wall and 2 x Side Wall fits 217cm/229.5cm height (SF7833)

10' Front Wall and 2 x Side Wall fits 192cm/204.5cm height (SF7834)

10' Front Wall and 2 x Side Wall fits 217cm/229.5cm height (SF7835)

13' Front Wall and 2 x Side Wall fits 192cm/204.5cm height (SF7836)

13' Front Wall and 2 x Side Wall fits 217cm/229.5cm height (SF7837)

	7 Foot (SF7771)	10 Foot (SF7772)	13 Foot (SF7773)
<b>Approx. Pack size:</b>	110cm x 10cm x 20cm	162cm x 10cm x 20cm	208cm x 10cm x 20cm
<b>Approx. Weight:</b>	4.6kg	5.7kg	6.8kg

The Protekta Sun Canopy is designed for those who require a simple, easy to use, fair weather sunshade. The canopy simply unfolds from the protective bag, the frame attaches in position and after pegging the guy ropes, you are ready to start your holiday.

Optional  
Roof  
Support/Leg  
Pole available  
(DT0092)



... simple, easy to use ...



PROTEKTA - shown with Wall Pack

# .... COMPLEMENT YOUR SUNNCAMP AWNING WITH OUR AWNING WINDBREAK

## SUNNSHIELD UNIVERSAL SUN CANOPY 390

[SF8003]

## SUNNSHIELD UNIVERSAL SUN CANOPY 280

[SF8002]

## SUNNSHIELD UNIVERSAL SUN CANOPY 240

[SF8001]

### Features:

- Attaches directly to caravan
- Three sizes available
- Maximum front height 200cm



	390	280	240
<b>Product Dimensions</b>	390cm x 218cm	280cm x 218cm	240m x 218cm
<b>Approx. Pack size:</b>	65cm x 11cm x 11cm	65cm x 10.5cm x 10.5cm	65cm x 10cm x 10cm
<b>Approx. Weight:</b>	4.9kg	3.7kg	3.4kg

A simple sun canopy, with beading, which may be used on its own by fitting directly onto your caravan.

Our 390 and 280 models are also compatible with our 2017/2018/2019 Ultima Air Grande 390, Ultima Air Super Deluxe 390 and Ultima Air Super Deluxe 280 awnings and zip onto the front of each awning to offer an additional awning sun canopy.

## AWNING WINDBREAK

[SF7838]



### Features:

- Beading to attach to caravan
- Aluminium poles
- **Size 500 x 140cm approx.**
- **Pack size: 57x15cm/Weight 2.9kg approx.**

Compatible with all Sunncamp Porch Awnings



## OPTIONAL EXTRAS - Poled Awnings

Model	Luxury Awning Carpet	Breathable Groundsheet	Veranda Pole	Rear Pad Poles	Canopy Pole Set	Roof Pole	Inner Tent	Low Wall Set	High Wall Set	Roof Support Leg Pole	Annexe	Awning Windbreak
Ultima 390 Classic	BC1008	DT0038	N/A	DT0052	DT0032	✓ Included	SF7024	X	X	X	X	SF7838
Ultima Versara 390	BC1008	DT0038	DT0091-B	DT0052	DT0032	✓ Included	SF7024	X	X	X	SF1913	SF7838
Ultima 260 Classic	BC1004	DT0037	N/A	DT0052	DT0032	✓ Included	SF7024	X	X	X	X	SF7838
Ultima Versara 260	BC1004	DT0037	DT0091-B	DT0052	DT0032	✓ Included	SF7024	X	X	X	SF1913	SF7838
Swift Deluxe 390	BC1008	DT0038	N/A	DT0052	DT0032	DT0091-B	SF1905	X	X	X	X	SF7838
Swift Deluxe 325	BC1006	DT0053	N/A	DT0052	DT0032	DT0091-B	SF1905	X	X	X	X	SF7838
Swift Deluxe 260	BC1004	DT0037	N/A	DT0052	DT0032	DT0091	SF1905	X	X	X	X	SF7838
Swift Deluxe 220	BC1003	DT0046	N/A	DT0052	DT0032	DT0091	SF1905	X	X	X	X	SF7838
Swift Canopy 390	BC1008	DT0038	N/A	X	X	DT0091-B	X	X	X	X	X	SF7838
Swift Canopy 330	BC1006	DT0053	N/A	X	X	DT0091-B	X	X	X	X	X	SF7838
Swift Canopy 260	BC1004	DT0037	N/A	X	X	X	X	X	X	X	X	SF7838
Swift Canopy 200	BC1027	DT0102	N/A	X	X	X	X	X	X	X	X	SF7838
Protekta 7'	X	X	N/A	X	X	X	X	SF7832	SF7833	DT0092	X	SF7838
Protekta 10'	X	X	N/A	X	X	X	X	SF7834	SF7835	DT0092	X	SF7838
Protekta 13'	X	X	N/A	X	X	X	X	SF7836	SF7837	DT0092	X	SF7838



# SILHOUETTE MOTOR AIR 225 PLUS (SF7866)

# SILHOUETTE MOTOR AIR 250 GRANDE (SF7867)

### Features:

- Zipped rear access panel
- Access zip in rear tunnel
- Tunnel privacy screen
- Extra wide roll back front door
- 225 Plus Model – large side window
- 250 Grande Model – large side door with window and canopy option
- Eyebrow porch
- SunnCamp's enhanced roof profile (ERP)
- Curtains on all windows
- Sewn in groundsheet
- Cable entry point and tidy system
- **Fits Motorhomes 225cm - 240cm**
- **225 - Pack size: 74 x 32cm/Weight: 10kg approx.**
- **250 Grande - Pack size: 78 x 34cm/17kg approx.**

### Floor Plans

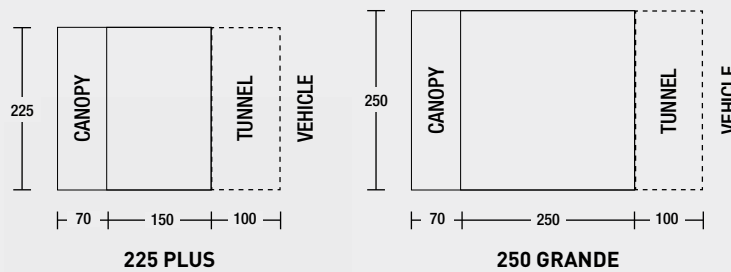

**Includes Pump**  
with gauge and dump valve 

**Includes AIR Storm Bars** **x1**  **225**

**Includes AIR Storm Bars** **x3**  **250**

**Includes Storm Buckles & Straps** 

**Includes Figure of 8 Fixing** 



**SILHOUETTE MOTOR AIR 225 PLUS**



**SILHOUETTE MOTOR AIR 250 GRANDE**



... plenty of features!

# SWIFT VAN 325 TALL (SF8045)

# SWIFT VAN 325 LOW (SF8044)

### Features:

- Wheelchair access
- Airflow doorways
- Zipped rear access panel
- Curtains on all windows
- Tunnel privacy screen
- Sewn in groundsheet
- Central clip privacy curtain
- Cable entry point and tidy system
- **Fits Motorhomes: Tall: 240cm – 270cm**  
**Low: 180cm – 210cm**
- **Pack size: 80cm x 28cm/Approx. Weight 11kg**

**Optional  
2 berth  
inner tent  
available  
(SF1905)**

### Floor Plan

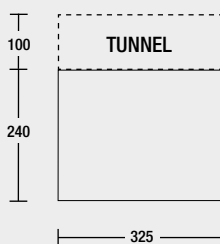

**Includes**  
Storm Buckles 

**Includes**  
Figure of 8 Fixing 

**Includes**  
Roof Poles  x1

Created and designed, based on our hugely successful range of Swift Deluxe caravan awnings, our SWIFT VAN awning is easy to erect, stylish and fantastic value for money.

Available in a 'Tall' and 'Low' tunnel height with airflow doorways and a roll up front door (with canopy option) this new motorhome awning for 2019 is sure to be a firm favourite!





# TOURER 335 MOTOR PLUS TALL (SF8012)

# TOURER 335 MOTOR PLUS LOW (SF8011)

## Features:

- Wheelchair access
- Zipped rear access panel
- Tunnel privacy screen
- Front panel with roll back doors
- Curtains on all windows
- Eyebrow porch
- Sewn in groundsheet
- Access zip in rear tunnel
- Sleeps 2 with optional inner tent
- Steel and fibreglass frame
- Cable entry point and tidy system
- **Fits Motorhomes: Tall: 240cm - 270cm Low: 180cm - 210cm**
- **Pack size: 28 x 84cm/Weight 19kg approx.**

## Floor Plan

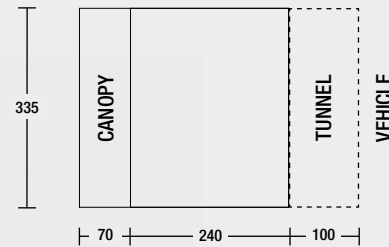

Includes Storm Buckles 

Includes Figure of 8 Fixing 



Optional inner tent available (SF7716)

The Tourer is ideal for family or short stay holidays ...

Created, designed and based on our bestselling Tourer model is now available in two heights for 2019 and now has a side door with wheelchair access.

The Tourer is ideal for family or short stay holidays and can be utilized with our optional two berth inner tent for storage or as an extra sleeping area.

The large front canopy provides protection to the front doorway panel and the front vented section/side window panels offer ventilation throughout.





## LODGE 200 MOTOR (SF7776)

### Features:

- Roll up front door with canopy option (poles optional extra)
- Sewn in groundsheet
- Curtains on all windows
- Side window with ventilation
- Fibreglass frame
- **Fits Motorhomes up to 240cm**
- **Pack size: 20 x 69cm/  
Weight 8.1kg approx.**

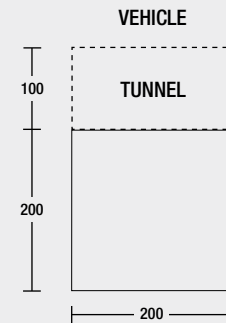
### Floor Plan



Includes  
Figure of 8 Fixing 

Our smallest motor annexe is compact yet packed with useful features and affordable. The Lodge is easy to erect and take down.



Side door  
with  
wheelchair  
access





SunnCamp



# SILHOUETTE 225 MOTOR PLUS (SF7870)

### Features:

- Large side window
- Zipped rear access panel
- Extra wide roll back front door
- Eyebrow porch
- Tunnel privacy screen
- Sewn in groundsheet
- Cable entry point and tidy system
- **Fits up to 240cm**
- **225 Plus - Pack size: 74cm x 23cm x 23cm approx. Weight 9kg approx.**

### Floor Plan

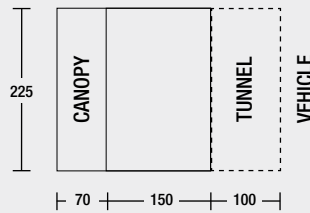

Includes Storm Buckles



Includes Figure of 8 Fixing



Compact and ideal for people who require a straightforward uncomplicated motor annexe. The Silhouette has plenty of features including an extra wide front door, large side window, eyebrow porch and sewn in groundsheet.



Large side window with ventilation



SILHOUETTE 225 MOTOR PLUS

The Silhouette has plenty of features ...





# MOTOR BUDDY 300XL (SF8015)

# MOTOR BUDDY 250 (SF7777)

### Features:

- Curtains on all windows
- Zipped rear access panel
- Side panels include half window half mesh ventilation
- Fibreglass frame
- 300 XL model – integral annexe with inner tent included
- **Fits Motorhomes up to 240cm**
- **250 model - Pack size: 19cm x 76cm/ Weight 7.8kg approx.**
- **300XL model - Pack size: 77cm x 26cm/ Weight: 15.1kg approx.**

The success of our Motor Buddy drive away motor awning continues and for 2019 it is now available in two sizes, the original 250 and the all new 300XL model. Both offer similar features however the 300XL comes with a fixed annexe which is ideal for sleeping or extra storage.

### Floor Plans

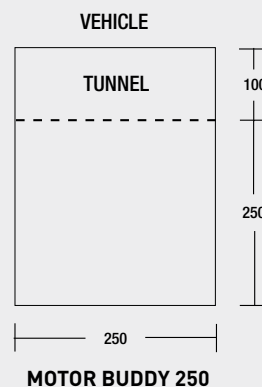
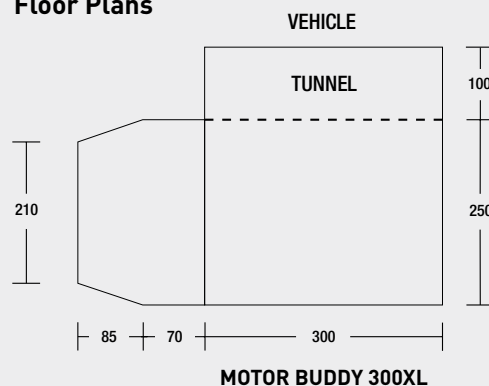

Includes Figure of 8 Fixing 



... our new 300XL model comes with a fixed annexe which is ideal for sleeping or extra storage



## SWIFT VAN CANOPY 260 LOW (SF8016)

## SWIFT VAN CANOPY 260 TALL (SF1915)

### Features:

- Dual beading 6.2mm/4mm
- Steel and fibreglass frame
- Side windows
- **Fits Vans**    **Low:185-200cm**  
                      **Tall: 250-265cm**
- **Approx. pack size: 77cm x 15cm/Approx. Weight 6.5kg**

## SWIFT VERAO 260 VAN LOW (SF1916)

## SWIFT VERAO 260 VAN TALL (SF1917)

### Features:

- Dual beading 6.2mm/4mm
- Steel and fibreglass frame
- Side doors
- **Fits Vans**    **Low:185-200cm**  
                      **Tall: 250-265cm**
- **Approx. pack size: 69cm x 29cm/Approx. Weight 9.6kg**

**Optional  
2 berth  
inner tent  
available  
(SF1905)**

Our new Swift Van Canopy may not be drive away but its quick pitch and removal makes it an ideal fair weather shelter at a fantastic price!

### Floor Plan

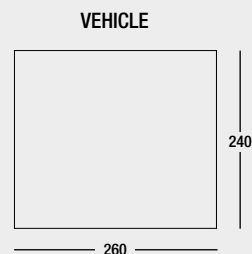

Our new Swift Verao 260 Van awning may not be drive away but its quick pitch and removal makes it an ideal shelter at a fantastic price!

### Floor Plan

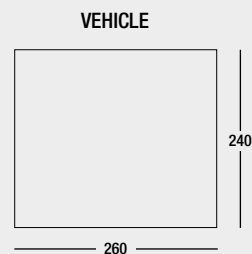

## OPTIONAL EXTRAS – Air Volution Motor Awnings and Poled Motor Awnings

### Air Volution Motor Awnings

Model	Luxury Carpet	Footprint/Groundsheet	Additional Air Storm Bars	Canopy Pole Set	Inner Tent	Drive Away Awning Kit	Magnetic Drive Away Awning Kit
Silhouette Motor Air 225 Plus	CC1139	FC1058	N/A	N/A	N/A	DT0084	DT0200
Silhouette Motor Air 250 Grande	CC1184	FC1077	N/A	DT0032	N/A	DT0084	DT0200

### Poled Motor Awnings

Model	Luxury Carpet	Footprint/Groundsheet	Roof Pole	Canopy Pole Set	Inner Tent	Drive Away Awning Kit	Magnetic Drive Away Awning Kit
Tourer 335 Motor Plus Low and Tall	N/A	FC1057	N/A	N/A	SF7716	DT0084	DT0200
Silhouette Motor 225 Plus	CC1139	FC1058	N/A	N/A	N/A	DT0084	DT0200
Swift Van 325 Low & Tall	N/A	DT0053	N/A	DT0032	SF1905	DT0084	DT0200
Swift Van Canopy 260 Low & Tall	BC1004	DT0037	N/A	N/A	N/A	DT0084	DT0200
Swift Verao 260 Van Low & Tall	BC1004	DT0037	DT0091	DT0032	SF1905	DT0084	DT0200
Motor Buddy 300XL	N/A	DT0068	N/A	DT0032	N/A	DT0084	DT0200
Motor Buddy 250	N/A	DT0056	N/A	DT0032	N/A	DT0084	DT0200
Lodge 200 Motor	N/A	N/A	N/A	DT0032	N/A	DT0084	DT0200

# SPECTRE 800 (SF1308) & EXTENSION (SF1310)

## Features:

- Roll up door with canopy option (poles optional extra)
- Airflow doorways
- Curtains on all windows
- Twilight inner tents
- Sewn in groundsheet (800 and 600 models)
- Loose groundsheet (extension)
- Fibreglass frame
- **Centre Height 220cm/Extension 210cm**
- **800 - Pack size: 76 x 38cm/Weight 24kg approx.**
- **Optional Extension - Pack size: 70 x 17cm/Weight 8kg approx.**

<b>Available Optional Extras:</b>	<b>800</b>
<b>Footprint Groundsheet</b>	FC1051
<b>Canopy Pole Set</b>	DT0032

## Floor Plan

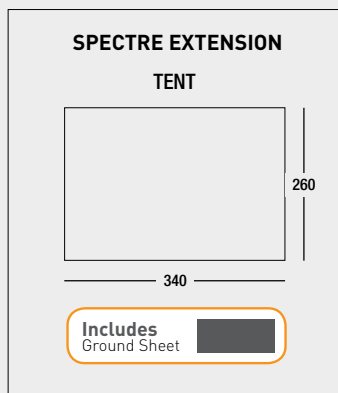
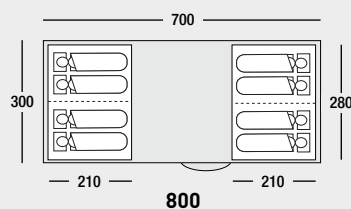

SPECTRE 800



SPECTRE EXTENSION

Ideal for medium to large family holidays ...

Ideal for medium to large family holidays and compatible with our optional Spectre Extension should you require extra space/living room. (800 model shown)



# SILHOUETTE 400 (SF7882)

# SILHOUETTE 200 (SF1329)

### Features:

- Extra wide front door
- Pre-fitted twilight inner tent
- Curtains on all windows
- Sewn in groundsheet
- Eyebrow porch
- Steel and fibreglass frame
- 400 model only – Side door with large window (roll up or canopy option)
- 400 model only – Integral zip away front canopy
- **Centre height: 200 model: 220cm: 400 model: 200cm**
- **400 - Pack size: 79 x 32cm/Weight: 16kg approx.**
- **200 - Pack size: 65 x 24cm/Weight: 11kg approx.**

### Floor Plan

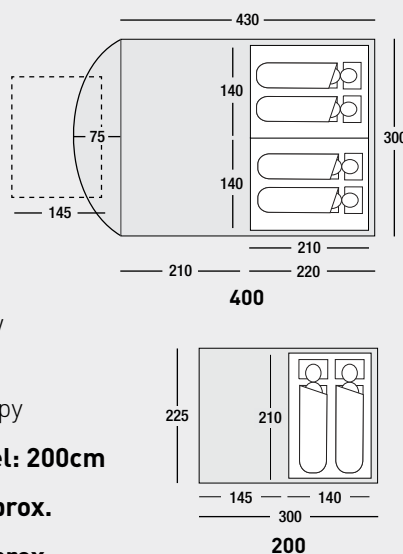

Includes Storm Buckles 

Includes Twilight Inner Tent 

Available Optional Extras:	400	200
Footprint Groundsheet	FC1085	FC1039
Luxury Carpet	N/A	CC1139
Canopy Pole Set	DT0032	N/A



SILHOUETTE 400

... both models come with pre-fitted inner tents, making set up easy ...



SILHOUETTE 200

Our Silhouette 200 model is perfect for the single camper or a couple whilst our Silhouette 400 model is perfect for a couple or a small family looking to go away on a camping holiday. Both models offer standing height and come with pre-fitted inner tents, making set up simple.

The Silhouette 400 additionally comes with a built in front canopy that offers protection from rain when entering your tent and a side door with large window.

## WINDJAMMER

(SF3005 BLUE) (SF3029 GREY)  
(SF3025 FERN)



Available  
in 3  
colour ways

### Features:

- Steel poles
- **Size: 500 x 140cm approx.**
- **Pack size: 56 x 9cm**
- **Weight: 2.5kg approx.**



## VERANO DL UNIVERSAL EXTENSION

(SF1186 GREY) (SF1353 FERN)



Available  
in 2  
colour ways

### Features:

- Front door rolls to the side
- Removable front panel
- Steel frame
- **Size: 345 x 185 x 210hcm approx.**
- **Pack size: 71 x 23cm/Weight: 13kg approx.**



## UTILITY LODGE

(SF3032)



### Features:

- Includes groundsheet
- Roll up front panel
- Rear vented panel
- Steel frame
- **Size: 210 x 140 x 210hcm approx.**
- **Pack size: 109 x 14cm**
- **Weight: 8.4kg approx.**





## GLOSSARY

### Non standard specification/features:

**Storm pole pocket:**

Certain models have an integral storm pole pocket and when used in conjunction with our optional upright poles (DT0052) can be used in certain conditions to aid stability and help water dispersal. Check individual entries for details.

**Air flow doorway:**

A separate ventilated mesh panel incorporated behind a door panel. This can be rolled back or zipped in place to aid airflow and reduce condensation whilst keeping bugs out. Check individual entries for details.

**Sewn in groundsheet:**

All tents and certain motor awnings models come with a sewn in groundsheet system offering protection from insects, dust, the elements etc. Check individual entries for details.

**Veranda option:**

Certain awnings come with a veranda option which allows you to fold the panel of your awning over a veranda pole to give a veranda effect. Simply locate the veranda pole (DT0091) in the pockets in the relevant panel. Check individual entries for details.

**Storm buckles and straps:**

Storm buckles and straps are provided as standard on all air volution models.

**Window lights:**

Certain awnings come with windows in the roof with velcro fastening curtains to enhance the light inside your awning. Check individual entries for details.

**Enhanced Roof Profile:**

SunnCamp's Enhanced Roof Profile is utilized on caravan awnings and motor awnings manufactured in our 300D Pro-Tek fabric, further complementing the appearance and providing a homely ambience.

**Privacy Screen:**

Many of our motor awnings come as standard with a simple divider for the tunnel area which may be attached to divide the tunnel to offer privacy. Check catalogue entry for details.

**Multi-Zip Curtains:**

You may have your curtains fully open, fully close, veranda style or traditional style.

### Standard specification/features:

**Waterproof flysheet:**

6000MM HH (except Protekta range). All flysheets comply with the latest British Standard Flame Retardant Regulations.

**Taped seams:**

Main seams have been heat sealed with a polyurethane tape to give extra waterproof protection. Remaining seams and seams where tape has been broken during production and/ or to necessitate tie points, suspension points etc., should have seam sealant applied to them.

**Zips:**

Heavy duty SunnCamp zips are used throughout our range of products.

**Windows:**

All windows have curtains with velcro or toggle fixings.

**Colour coded poles and sleeves:**

Where a product has different length poles, to aid setup our poles and sleeves are colour coded.

**Rear pads:**

SunnCamp porch awnings come as standard with rear weather pads. Rear weather pad poles are not standard – please check individual entry for details.

**Draught skirt:**

A PVC or PE draught skirt (varies over models) is included as standard with all porch awnings (except Swift Canopy and Protekta models).

**Figure of 8:**

Supplied as standard on all motor awnings.

**Daylight panel:**

Where necessary tents have been designed with a daylight panel (light colour fabric over the living area) enhancing light access.

**Cable entry point and tidy system:**

All tents come with a zipped entrance allowing a mains lead to run safely into your tent. The cable tidy system which consists of velcro fastening points allows the cable from a mains powered light to be stored safely.

**Twilight Inner Tents:**

Where inner tents are provided, they have been darkened for extra comfort.







SunnCamp Dealer/Stockist:



SunnCamp UK

[www.sunncamp.co.uk](http://www.sunncamp.co.uk)

The weights, sizes, plans and colours shown in this brochure are given as an indication and are approximate. SunnCamp reserve the right to alter specifications as considered necessary without notice.



ICON AIR® ESTEEMED AIR®

ESTEEMED AIR - size 14